

ORIGINAL MINI ACCESSORIES. INSTALLATION INSTRUCTIONS.



Mud Flaps Retrofit Kit MINI Countryman (R 60)

Retrofit kit number

82 16 2 166 935 Front mud flaps set
82 16 2 156 545 Rear mud flaps set

Installation time

The installation time is **approx. 0.5 hours**. This may vary depending on the condition of the car and the equipment in it.

Important information

These installation instructions are primarily designed for use within the BMW dealership organisation and by authorised MINI service companies.

In any event the target group for these installation instructions is specialist personnel trained on MINI cars with the appropriate specialist knowledge.

All work must be completed using the latest MINI repair manuals, wiring diagrams, servicing manuals and work instructions, in a rational order, using the prescribed tools (special tools) and observing current health and safety regulations.

If you experience installation or function problems, restrict troubleshooting to approx. 0.5 hours for mechanical work and 1.0 hour for electrical work.

In order to reduce costs and avoid any additional expense, send a query immediately to Technical Parts Support via the Aftersales Assistance Portal (ASAP).

Quote the following information:

- Chassis number,
- Retrofit kit part number,
- A detailed description of the problem,
- Any work already carried out.

Do not archive the hard copy of these installation instructions since daily updates are made via ASAP!

Pictograms

 Denotes instructions that draw your attention to dangers.

 Denotes instructions that draw your attention to special features.

◀ Denotes the end of the instruction or warning text.

Installation information

Some of the installation steps are shown only on the left-hand side of the car, proceed in the same way on the right-hand side of the car.

All pictures show LHD cars; proceed accordingly on RHD cars.

Bonding surfaces must be cleaned with a cleaner and must be free from grease.

When carrying out bonding and drying work, ensure that the ambient temperature does not fall below or exceed 15 °C or 35 °C respectively.

The car may be driven after approx. **6 hours** and may be taken through a car wash after **48 hours**.

Special tools required

Table of contents

Section	Page
1 Preparatory work	4
2 Fitting the front mud flaps	5
3 Fitting the rear mud flaps	7
4 Concluding work and coding	11

1. Preparatory work

	ISTA No.
Conduct a brief test	---
Disconnect the negative pole of the battery	12 00 ...
The following components must be removed first of all	
Rear wheel left and right	33 10 300

2. Fitting the front mud flaps

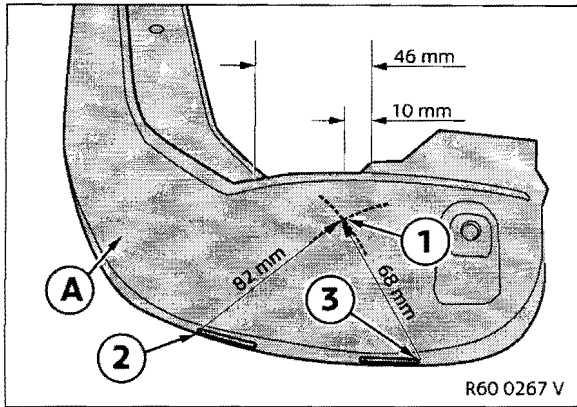

Only for cars with SZ Off-Road sill:

From the edge (1) of front mud guard A, measure **10 mm** and **46 mm** and mark each distance on the edge of front mudguard A using a pencil.

From the outer edge of long hole (2), measure a distance of **82 mm** using a fixed measuring caliper and only lightly score front mud guard A. From the outer edge of long hole (3), measure a distance of **68 mm** using a fixed measuring caliper and only lightly score front mud guard A.

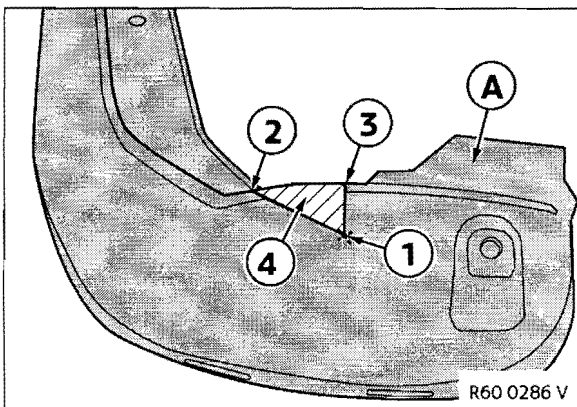

Link the cut point (1) with the previous markings (2) and (3) with a pencil and then cut out the resulting triangle (4) (hatched area) using suitable tools and deburr the cut edges.

Then, for all cars:

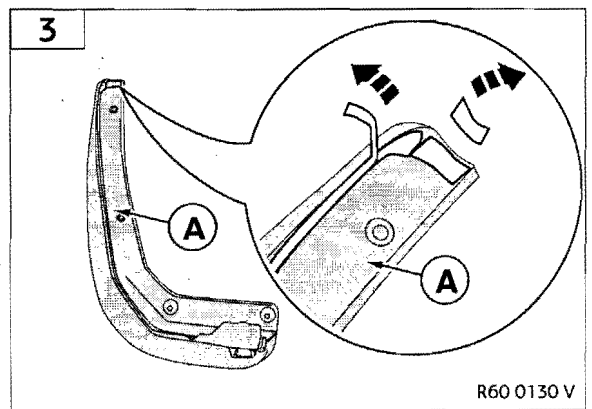
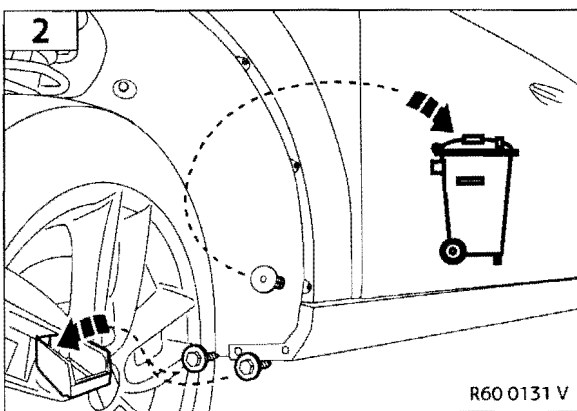
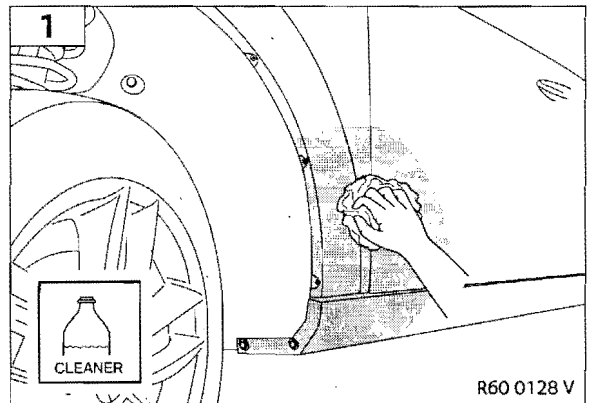
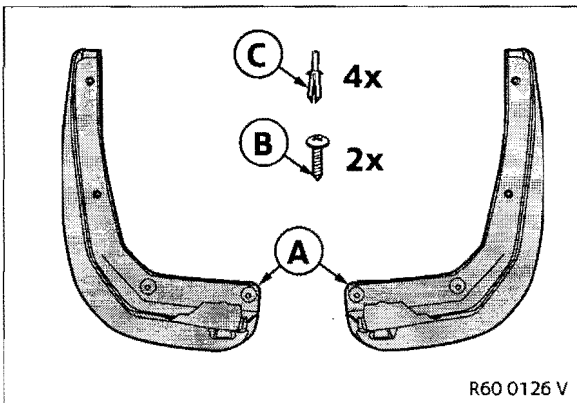

2. Fitting the front mud flaps

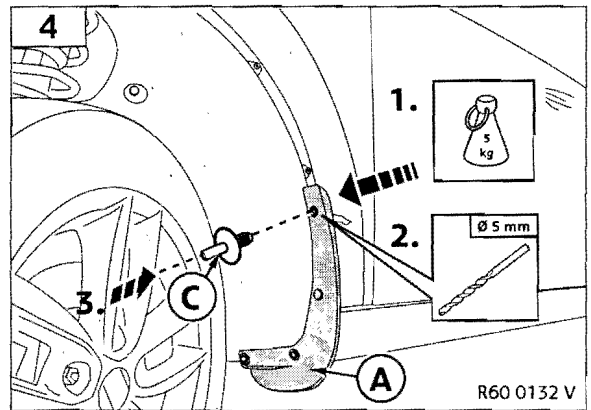
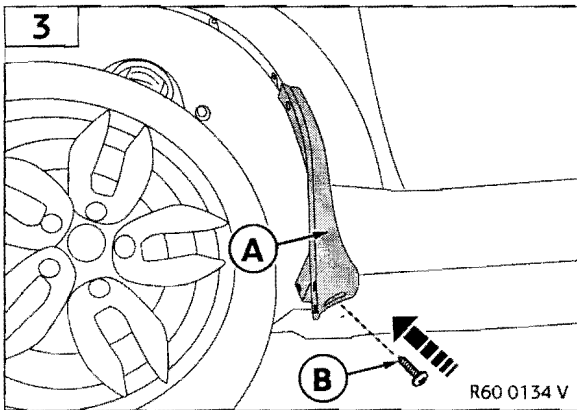
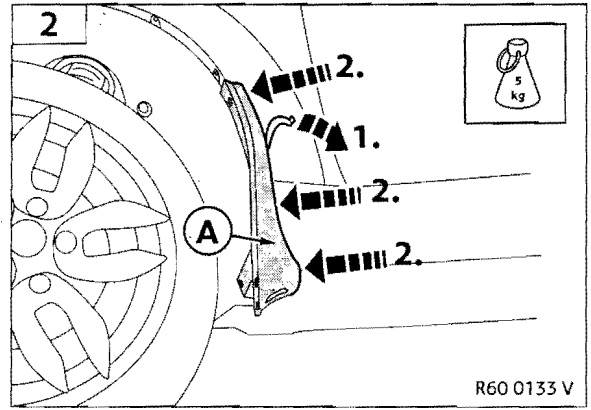
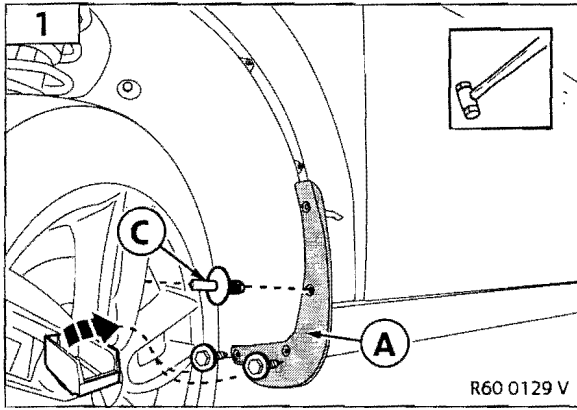

3. Fitting the rear mud flaps

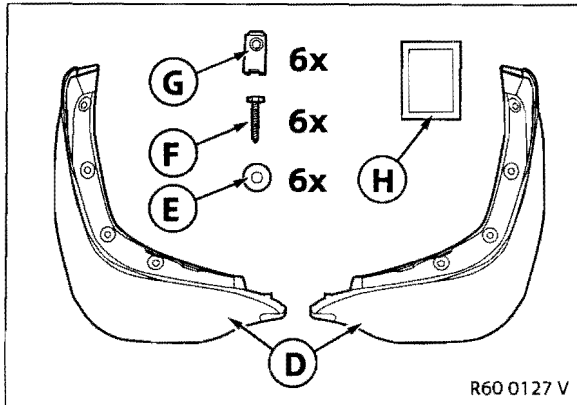

- D** Rear mud flap
- E** Shim
- F** Hexagon sheet metal screw
- G** Sheet metal nut
- H** Primer pad

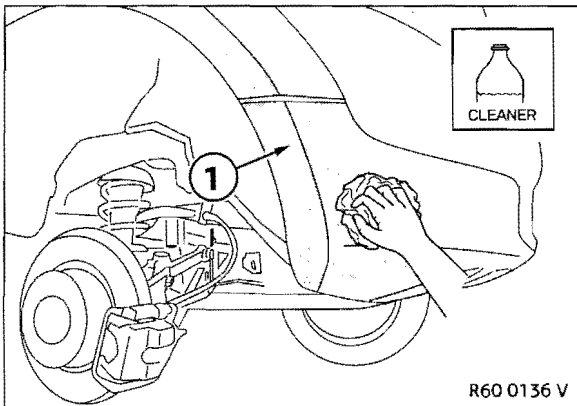

- ▶ Clean the area to be used before performing any bonding work. The bonding area must be completely dry, clean and free from dust and grease. ◀
Clean the bonding surfaces (1) thoroughly.

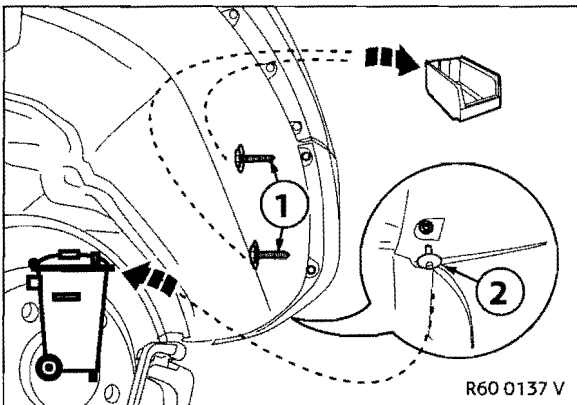

- ▶ The screws (1) will be reused. ◀
Unscrew the two screws (1) and keep them safe. Knock out the blind rivet (2) from the underside and throw it away.

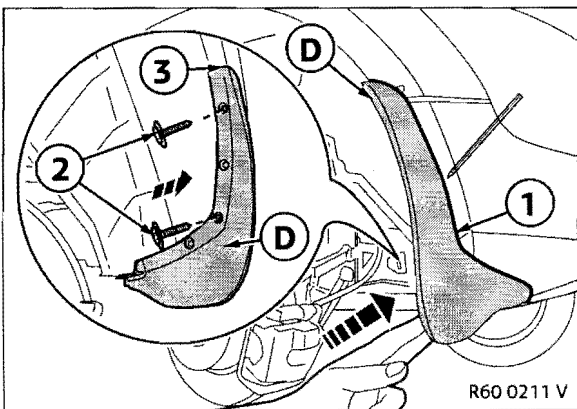

- ▶ The marking (1) must be removable without any residue. ◀
Fit on rear mud flap **D** and temporarily screw into position with both screws (2) so that the contour line matches the rear apron. Transfer and mark the contour (1) of the mud flap and the upper contour (3) of the mud flap on the wheel arch using a water-soluble pen.

3. Fitting the rear mud flaps

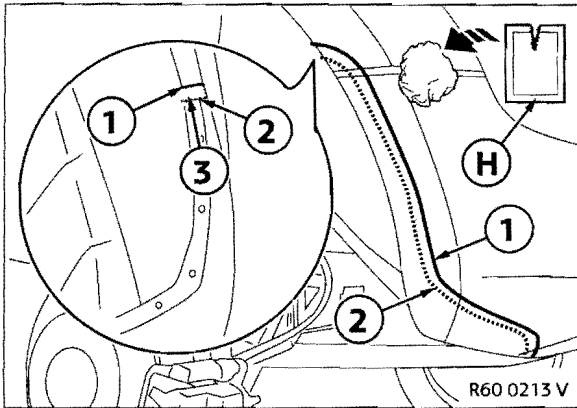

Do not apply primer **H** outside the drawn-on contour. If you do so, remove it immediately. ◀

Move the existing marking (1) by approx. 1 cm towards the dashed line (2) and draw it in. Then prime the surface between the line (1) and the dashed line (2) using primer **H**, and also prime the surface (3) in the wheel arch.

Remove the lines made by the water-soluble pen.

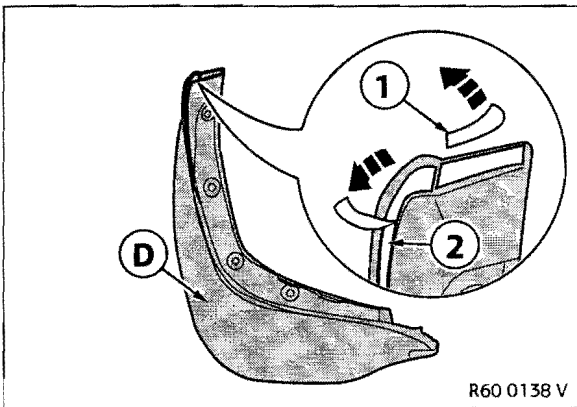

Completely remove the protective film (1) on the adhesive strips of rear mud flap **D**. Loosen the protective film (2) on the adhesive strip only by around 2-3 cm and fold it outwards.

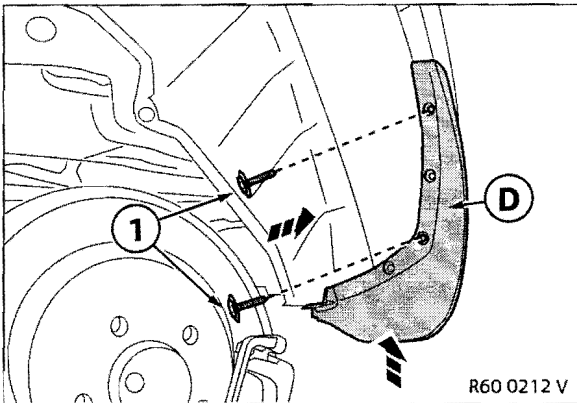

Only **slightly** screw in the screws (1) to ensure that rear mud flap **D** matches the car. ◀

Place rear mud flap **D** onto the wheel arch from underneath. Only **slightly** screw in the screws (1).

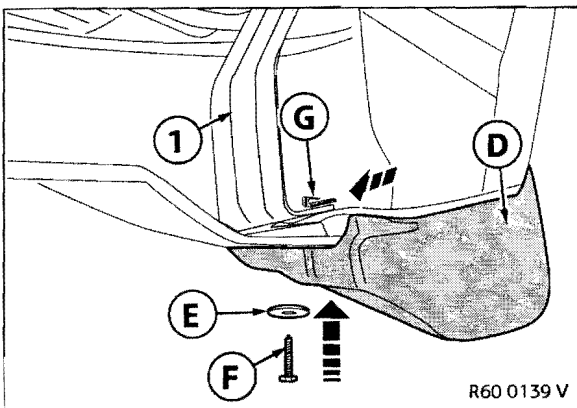

Only **slightly** screw in screws **F** to ensure that rear mud flap **D** matches the car. ◀

Place sheet metal nut **G** over the drill holes of spacer (1).

Insert hexagon sheet metal screw **F** together with shim **E** from underneath into the drill hole of rear mud flap **D**. Only **slightly** screw hexagon sheet metal screw **F** into sheet metal nut **G**

3. Fitting the rear mud flaps

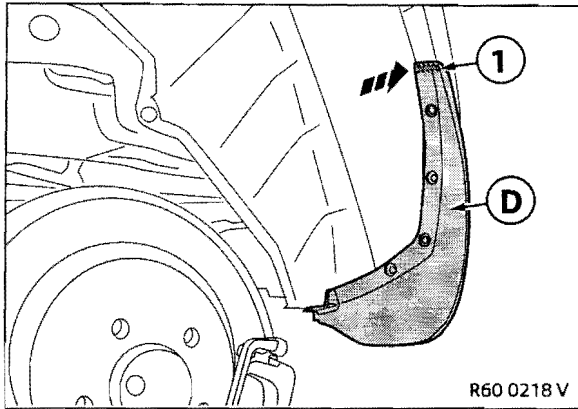

Firmly press the upper short adhesive strip (1) of rear mud flap **D** onto the wheel arch using your hand.

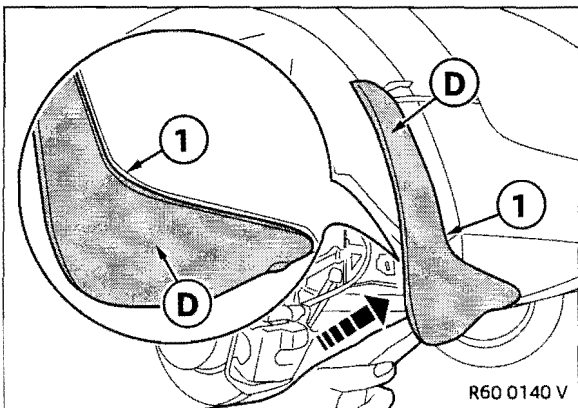

☐ When installing, note the contour (1) of rear mud flap **D** to the rear apron. ◀

Press rear mud flap **D** with one hand onto the wheel arch of the car and check the contour line (1) to the rear apron.

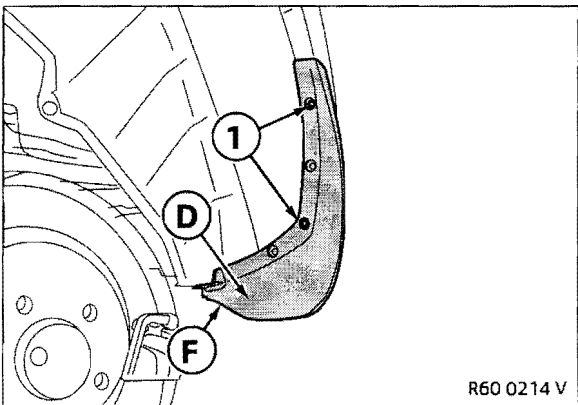

☐ When installing, note the contour of rear mud flap **D** to the rear apron. ◀

As soon as the contour matches, tighten the screws (1) and screw **F**.

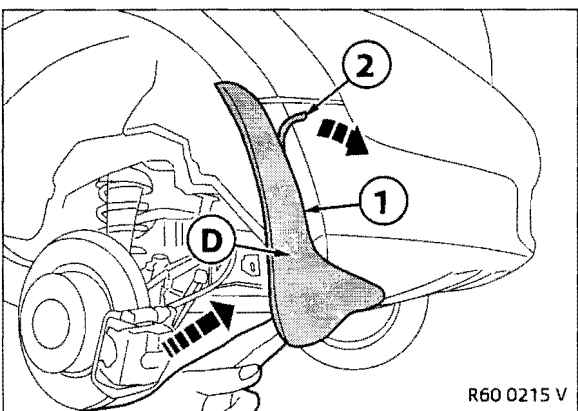

☐ When installing, note the contour (1) of rear mud flap **D** to the rear apron. ◀

Completely remove the red protective film (2) from rear mud flap **D** and press rear mud flap **D** with the other hand onto the wheel arch so that the contour (1) lies up against the rear apron.

3. Fitting the rear mud flaps

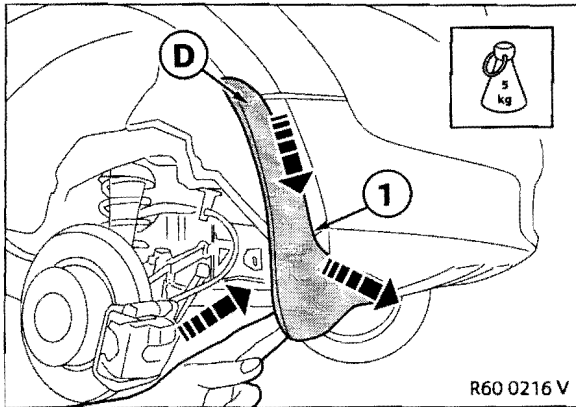

Move your hand from top to bottom along the edge (1) and thus press rear mud flap **D** with a force of **approx. 5 kg**, pressing in the opposite direction with the other hand.

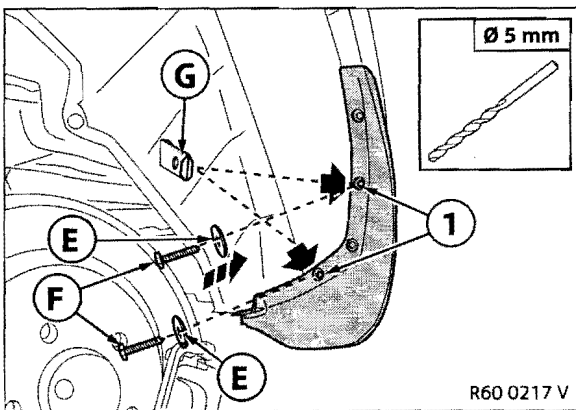

Drill holes (1) of diameter = **5 mm**.

Then insert hexagon sheet metal screws **F** together with shims **E** into both drill holes (1). Guide sheet metal nuts **G** from inside into the rear apron to the position of hexagon sheet metal screw **F**. Firmly tighten hexagon sheet metal screw **F**.

4. Concluding work and coding

This retrofit system does not require coding.

- Connect the battery
- Conduct a brief test

Re-fit the car components as required

