

ORIGINAL MINI ACCESSORIES.

INSTALLATION INSTRUCTIONS.



JOHN COOPER WORKS Tuning Kit Retrofit Kit.

MINI Clubman (F54)

MINI Countryman (F60)

Retrofit kit number

11 12 2 450 143	Tuning kit for F60 All4
11 12 2 450 144	Tuning kit for F60
11 12 2 445 893	Tuning kit for F54
11 12 2 445 894	Tuning kit for F54 All4

Installation time

The installation time is **approx. 3.0 hours**. This may vary depending on the condition of the car and its equipment package.

The installation time shown does not include any time spent on programming/coding.

The calculation of the total costs for the programming time must be factored into the calculation of retrofitting costs (must not be invoiced under the warranty).

Important information

These installation instructions are primarily designed for use within the BMW dealership organisation and by authorised MINI service companies.

In any event the target group for these installation instructions is specialist personnel trained on MINI cars with the appropriate specialist knowledge.

All work must be completed using the latest MINI repair manuals, wiring diagrams, servicing manuals and work instructions, in a rational order, using the prescribed tools (special tools) and observing current health and safety regulations.

If you have a very sporting driving style, MINI recommends that you install the larger 17" JCW braking system which delivers better thermal performance.

If you experience installation or functional problems, restrict troubleshooting to approx. 0.5 hours for mechanical work and 1.0 hour for electrical work.

To avoid unnecessary extra work and/or costs, send an inquiry straight away to the technical parts support team via the Aftersales Assistance Portal (ASAP).

Quote the following information:

- VIN,
- retrofit kit part number,
- a detailed description of the problem,
- any work already carried out.

Do not archive the hard copy of these installation instructions, since daily updates are provided via ASAP!

Pictograms

 Denotes instructions that draw your attention to dangers.

 Denotes instructions that draw your attention to special features.

◀ Denotes the end of the instruction or other text.

Installation information

Ensure that the cables and/or lines are not kinked or damaged as you install them in the car. Costs incurred by this will not be reimbursed by BMW AG.

Additional cables/wires that are installed must be secured with cable ties. If the specified PIN chambers are occupied, bridges, double crimps, or twin-lead terminals must be used.

All illustrations show LHD (left-hand drive) cars; proceed similarly on RHD (right-hand drive) cars.

After the installation work, the retrofit must be programmed / coded via the – **Conversions** – path.

Some of the installation work is shown only on the F60. Proceed in the same way on the other cars.

Request an activation code

The activation code must be requested using the document enclosed with the tuning kit in the envelope marked **M** via the Aftersales Assistance Portal (ASAP) in the "Service/Technology" section under "Sweeping Technologies", menu item "Request Tuning Kit FSC".

Workshop certificate

Print out the workshop certificate at the end of the installation instructions, fill it in and give it to the customer.

Radio remote control

The remote control **E** for the silencer with flap must be given to the customer along with its packaging and its function must be explained.

Certificate

Certificate **I** must be filled out and given to the customer.

Special tools required

17 2 051, no information

Table of contents

Section	Page
1. Tuning kit parts list	4
2. Preparatory work	5
3. Install the wiring harness	6
4. Install the silencer with flap system	9
5. Install the tuning kit	10
6. Request an activation code	11
7. Concluding work and coding	12
8. Workshop certificate	13

1. Tuning kit parts list

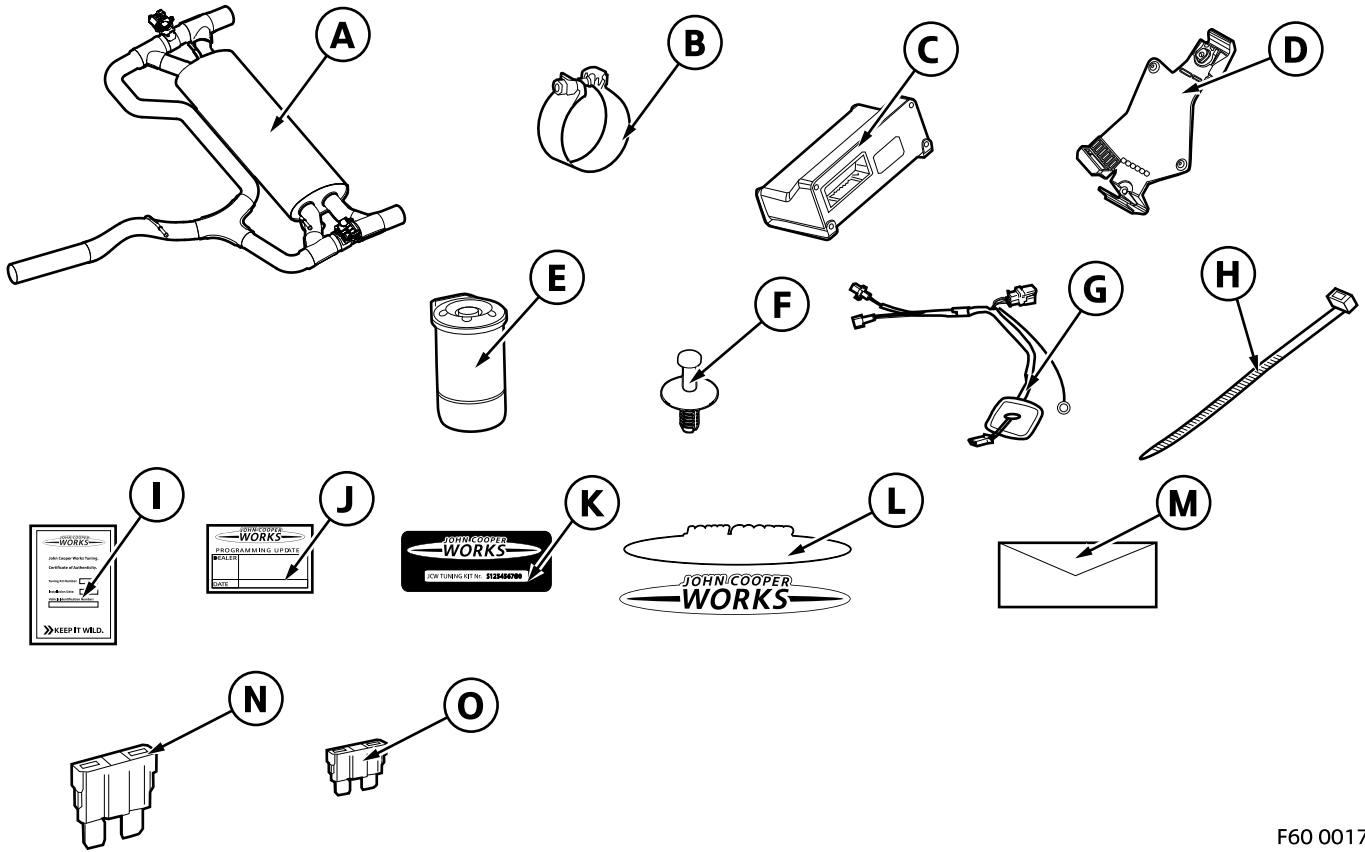

F60 0017 V

Legend

- A** Silencer with flap system
- B** Clamping ring
- C** Silencer with flap system receiver unit
- D** Receiver unit mounting **(for F54 cars without SA 4VA only)**
- E** Silencer with flap system remote control (including packaging)
- F** Plastic rivet (3 x) **(for F60 cars only)**
- G** Silencer with flap system wiring harness
- H** Cable ties (3 x)
- I** Certificate
- J** Sticker
- K** Bonnet badge
- L** Boot lid emblem **(for F60 cars only)**
- M** Envelope
- N** Fuse 5A
- O** Mini fuse 5A

2. Preparatory work

	ISTA/AIR No.
Disconnect the negative battery cable	12 00 ...
The following components must be removed first of all	
Finisher on the top tail panel	51 46 050
Luggage compartment floor trim	51 47 101
Luggage compartment wheel arch trim panels, left and right	51 47 161
Rear right side trim panel	51 43 002
Rear right door sill cover strip	---
Side footwell trim on right B pillar	---
Front right sill cover strip	51 47 000
Side footwell trim on right A pillar	51 43 075
Disengage the front power distribution box	61 14 ...
Exhaust system from standard separation point	18 00 018

3. Install the wiring harness

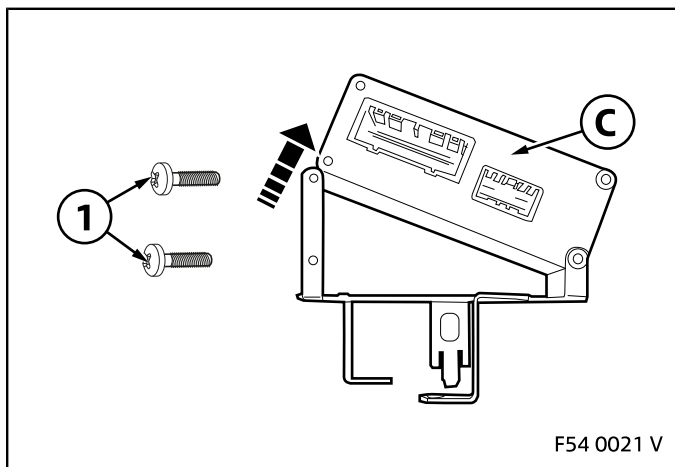

For F54 cars only

Undo the two screws (1) from the silencer with flap system receiver unit **C** and keep them safe. Turn the silencer with flap system receiver unit **C** upwards as shown in the figure.

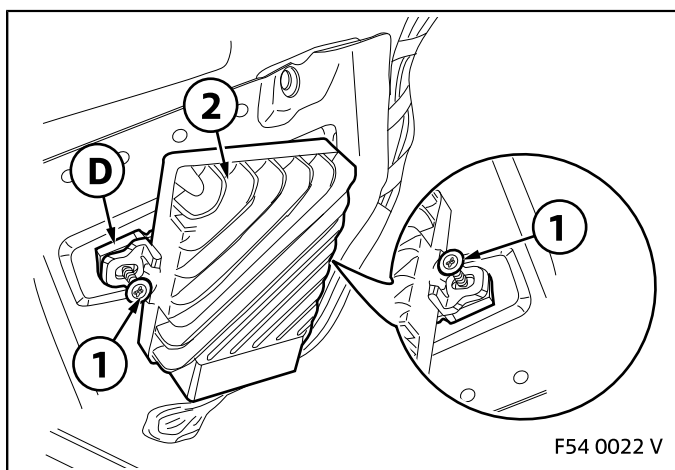

For F54 cars with SA 4VA only

☒ Cars with **SA 4VA** already have a control unit with the receiver unit mounting **D** on the left side of the boot. ◀

Unscrew the two screws (1) on the control unit (2). Then unclip the receiver unit mounting **D**.

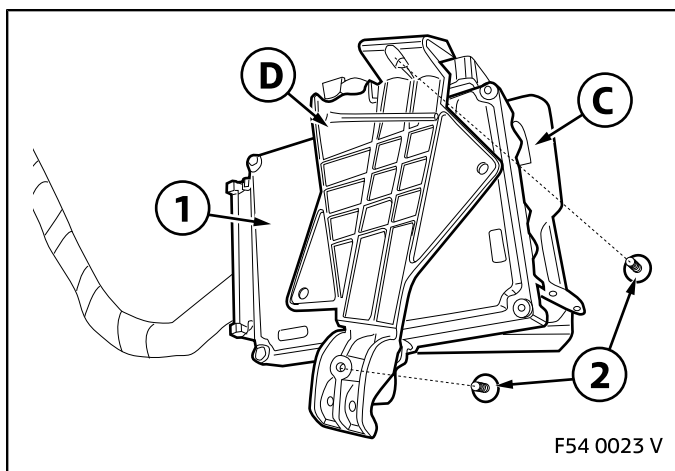

For all R54 cars

Fastened the receiver unit mounting **D** to the rear of the control unit (1). Fasten the silencer with flap system receiver unit **C** to the control unit (1) from the front. Turn the two existing screws (2) into the boreholes in the receiver unit mounting **D** from the front until they grip. Do not screw them in completely.

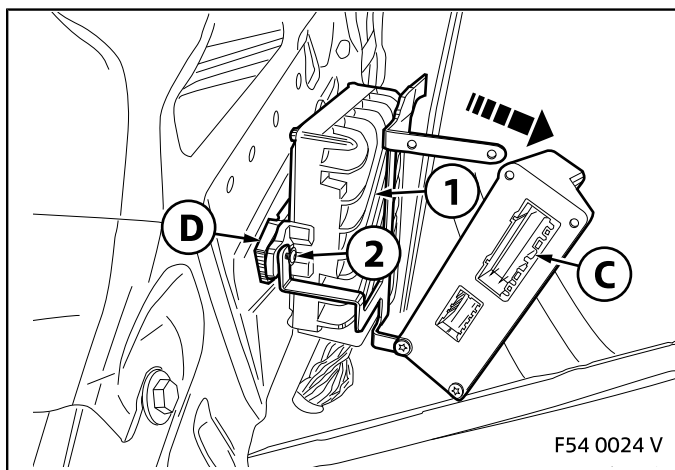

Clip the receiver unit mounting **D** back onto the car.

☒ To make the screw (1) easier to access, fold down the silencer with flap system receiver unit **C** as far as possible. ◀

Then secure both screws (1) and (2) using a suitable tool.

3. Install the wiring harness

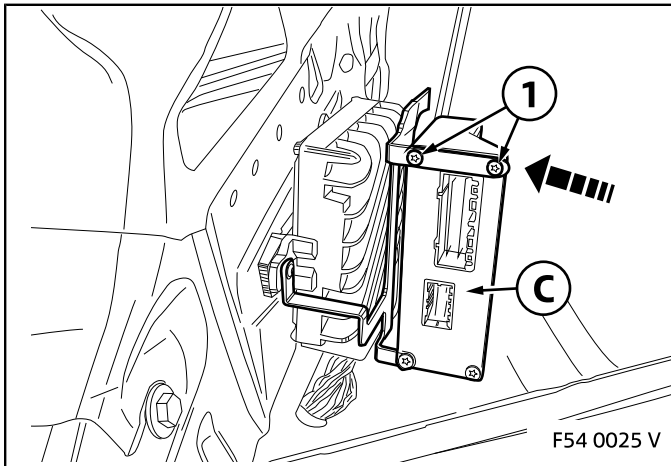

Unscrew the silencer with flap system receiver unit **C** and secure it with the two existing screws (1).

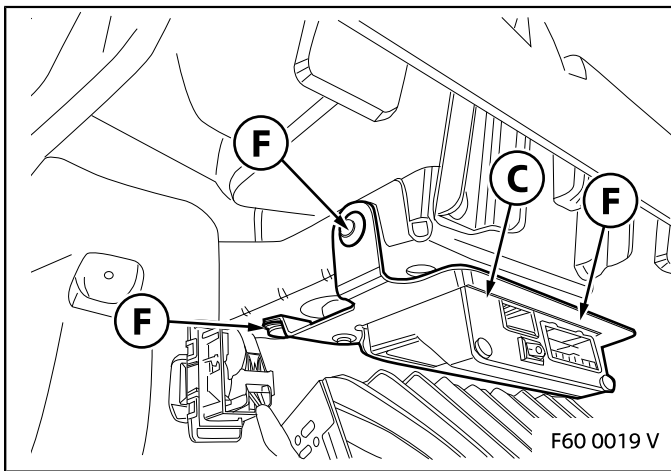

For F60 cars only

Secure this silencer with flap system receiver unit **C** with the three plastic rivets **F** to the left hand side of the boot above the amplifier as shown. One of the two rear plastic rivets **F** is not shown in the figure.

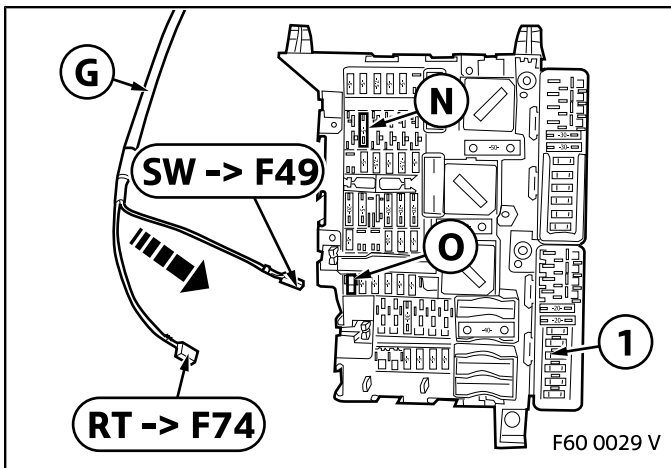

For all cars

Connect the red cable (**RT**) from wiring harness **G** to fuse plug **F74** in the front power distributor (1). Insert fuse **N** into slot **F74**.

Connect the black cable (**SW**) from wiring harness **G** to fuse plug **F49**. Insert fuse **O** into slot **F49**.

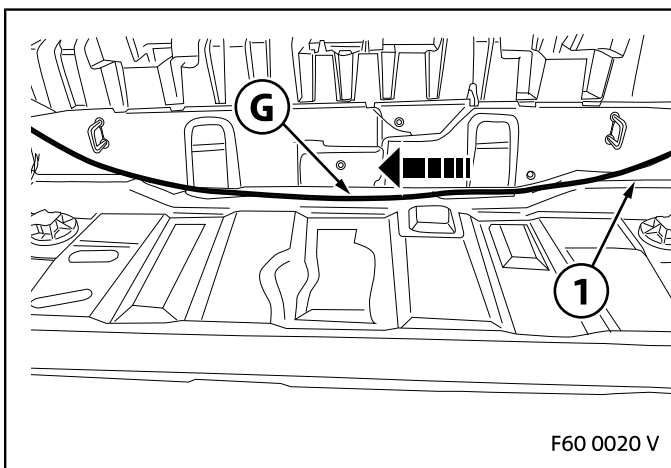

Route the wiring harness **G** to the rear of the boot and secure it in a suitable position with cable ties **H**. In the boot route it from the right-hand side to the left-hand side along the boot edge (1).

3. Install the wiring harness

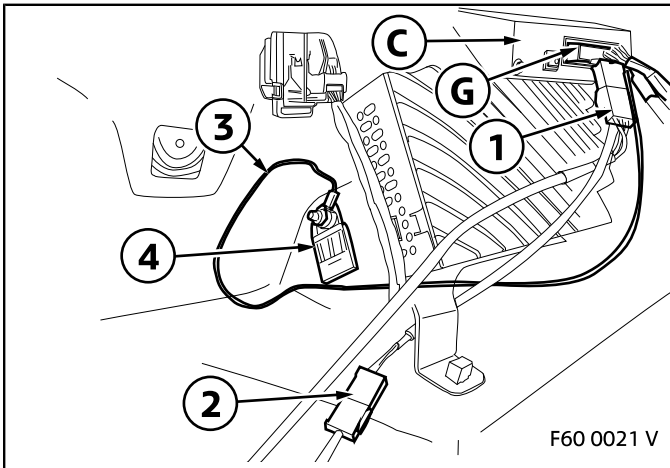

Connect wiring harness **G** to the silencer with flap system receiver unit **C**.

Disconnect the two plugs (1) and (2) from the wiring harness **G**.

Secure the earth cable (3) to the car's ground support point (4).

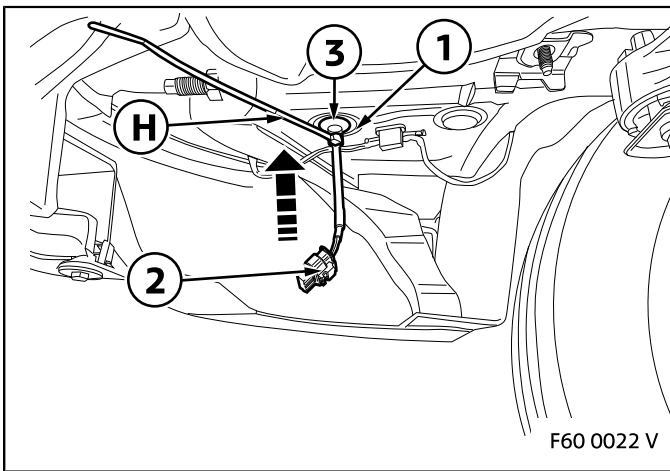

▶ Install the short silencer with flap system cable on the left of the car. Install the long silencer with flap system cable on the right of the car. ◀

Open the borehole (1) using a suitable tool. Route the removed silencer with flap system cable (2) from below through the opening up to the cable retaining bung (3). Insert the retaining bung and then secure it to prevent it sliding with a cable tie **H**.

Repeat the process on the opposite side.

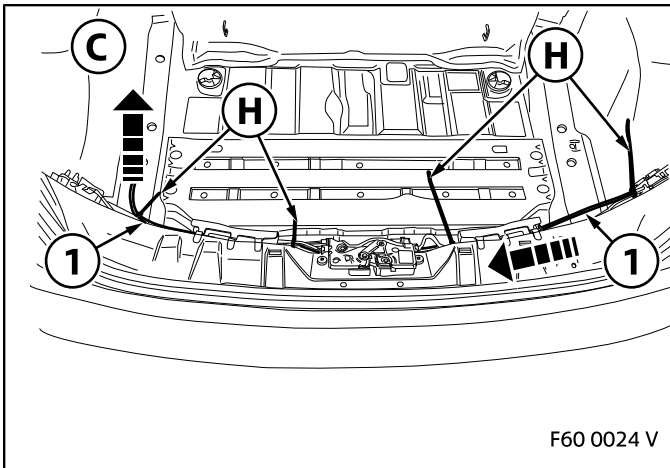

Route the silencer with flap system cable (1) from right to left and secure it to the edge of the boot floor with cable ties **H**. Route both silencer with flap system cables towards the receiver unit **C** (not shown) and secure them with a cable tie **H**.

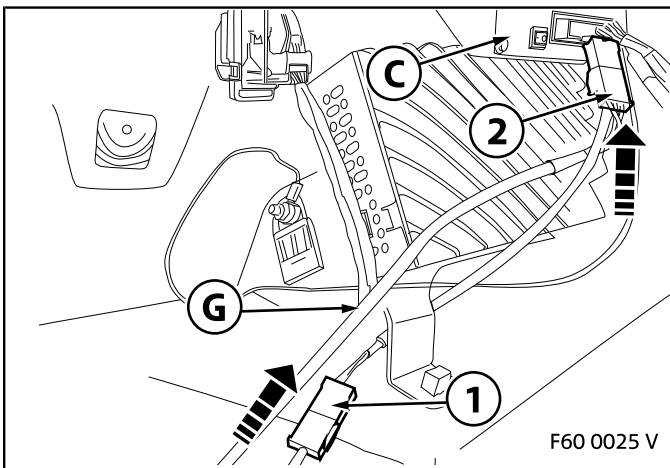

Reconnect the two plugs (1) and (2) on wiring harness **G** to the two sockets in the silencer with flap system receiver unit **C**. Connect the shorter silencer with flap system cable (2) to the shorter cable and the longer silencer with flap system cable (1) to the longer cable.

4. Install the silencer with flap system

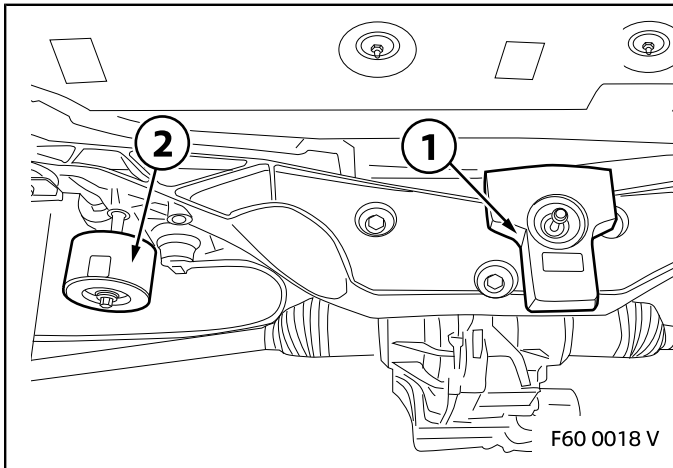

Cars with automatic transmission only

Remove the two vibration absorbers (1) and (2), they are no longer required.

For all cars

Fit silencer with flap system **A** as described in **ISTA/AIR No. 18 12 030**.

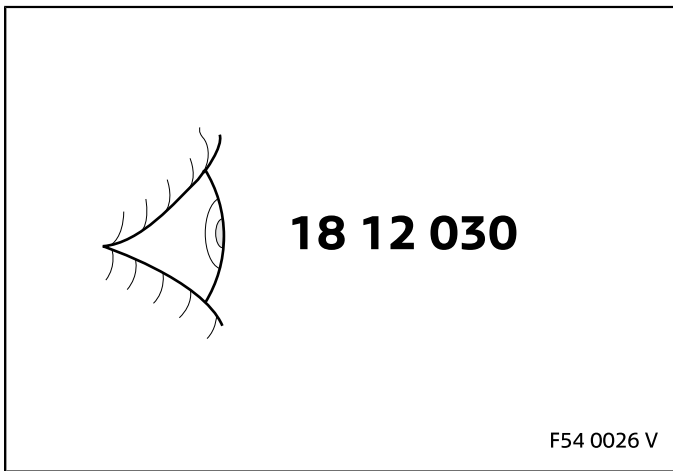

5. Install the tuning kit

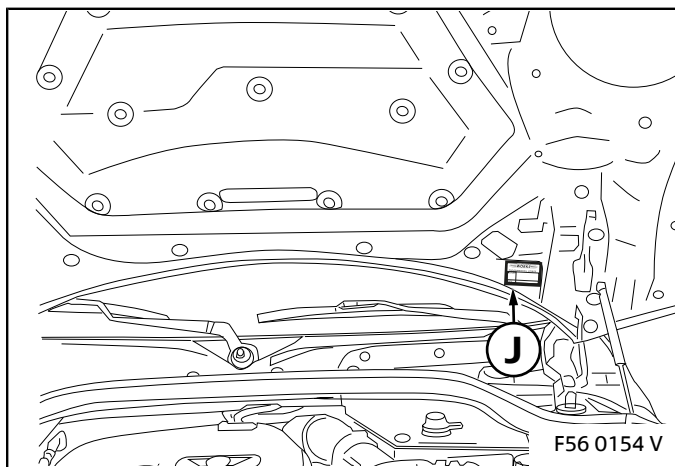

▶ The bonding surfaces must be completely dry, clean, and free from wax or grease. ◀

Enter the dealership and date on sticker J.

Affix sticker J on the right lower underside of the bonnet.

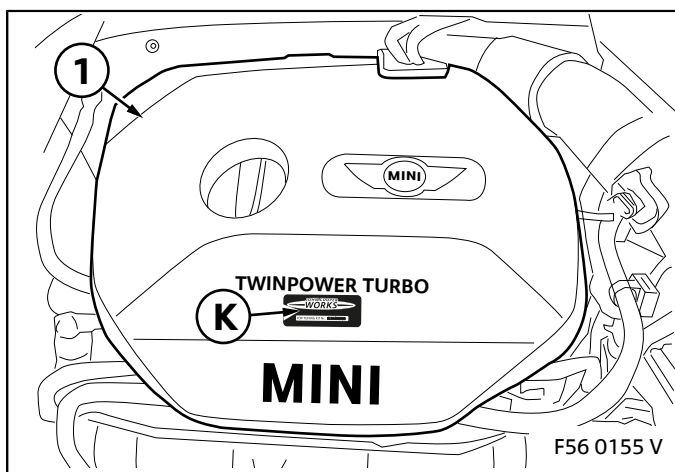

▶ The bonding surfaces must be completely dry, clean, and free from wax or grease. ◀

Position bonnet badge K in the centre of the bonnet (1).

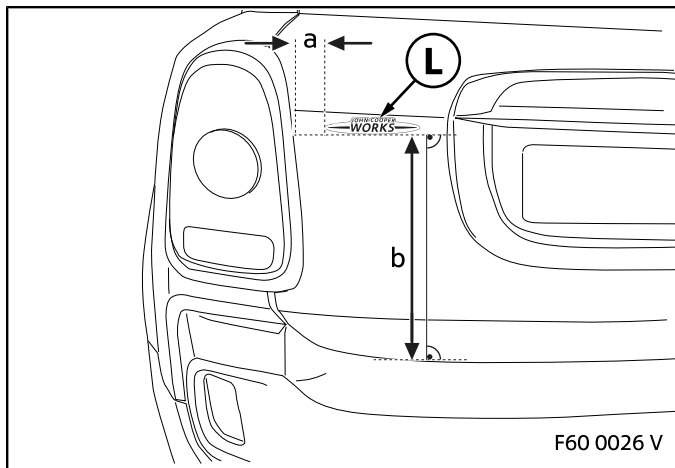

For F60 cars only

▶ The bonding surfaces must be completely dry, clean, and free from wax or grease. ◀

Find the position of the boot lid emblem L as follows:

a = 39.0 mm: distance between the left edge of the boot lid and the left end of the emblem

b = 329.0 mm: distance between the bottom of the boot lid and the bottom of the emblem

6. Request an activation code

Suchbegriffe
Fahrgestellnummer

Suche

>Erweiterte Suche

Home
Service / Technik

Sweeping Technologies
Download Freischaltcodes
Information
Anfrage Reparatur FSC
Anfrage Tuning-Kit FSC

Suche

Fahrgestellnummer
SN
Key

ZK93753
BPF0000
HK2JUV7710C

Download

1
2
3
4

F56 0158 V

▶ Note that entries are case sensitive. ◀

Remove the activation code document from envelope **M** and log into the ASAP portal. On the "Service/Technology" page, navigate to "Sweeping Technologies" and open the menu item "Request tuning kit enable code". Enter the last 7 digits of the chassis number in the box headed "Chassis number" (1). Enter the serial number in the field headed "SN" (2). Enter the alphanumeric combination from the tuning kit activation code document found in envelope **M** in the box headed "Key" (3). Then click the "Download" button (4).

Suchbegriffe
Fahrgestellnummer

Suche

>Erweiterte Suche

Home
Service / Technik

Sweeping Technologies
Download Freischaltcodes
Information
Anfrage Reparatur FSC
Anfrage Tuning-Kit FSC

Neue Suche

Info

Fahrgestellnummer
Ihre Händlernummer

ZK93753

Anzahl ausgewählter Codes

1

Freischaltcodes anzeigen

Ihre ausgewählten FSCs

Fahrgestellnummer	OrderID	Teilenummer	Upload Datum		
ZK93753	000000	Tuning Kit	19 Oct 2009 15:17		

1

F56 0159 V

⚠ If you enter the data incorrectly 10 times, the certificate will be blocked. ◀

Prior to downloading the activation code, you absolutely must check the chassis number and cancel the request if there are any mistakes. Save the activation code to a suitable storage medium and keep it ready for the programming process.

Once the activation code has been generated, you are automatically forwarded to the "Download Activation Codes" area (1).

7. Concluding work and coding

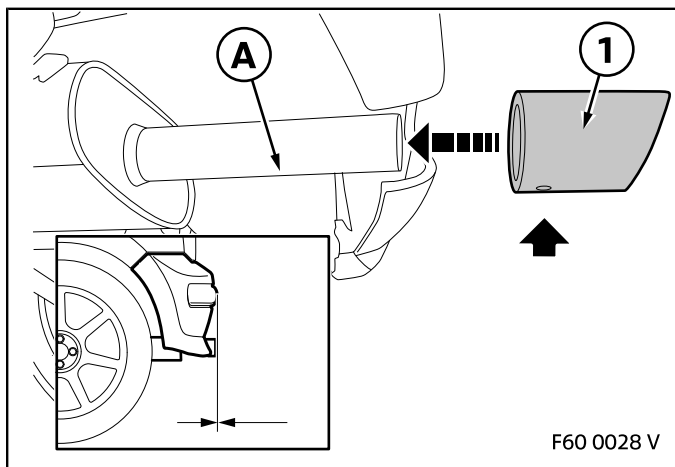

- ▶ The exhaust pipe trims (1) must be aligned centrally and parallel and must not extend beyond the bodywork parts above them. ◀

Align the exhaust pipe trims (1) flush with the bodywork parts situated above them and tighten them with a torque of **3 Nm**.

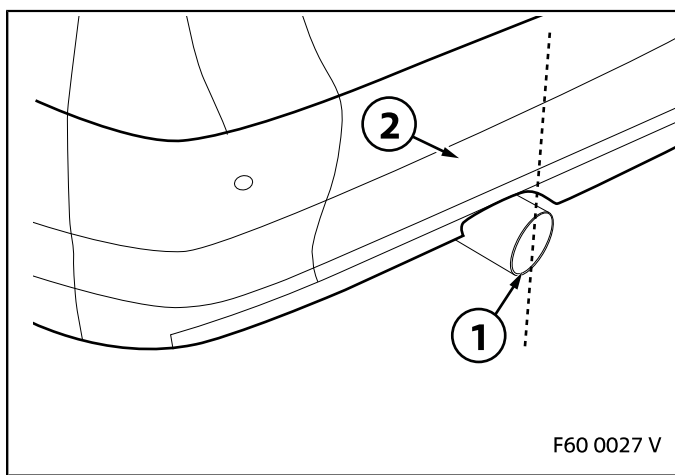

- ▶ During installation and also during vehicle use (thermal expansion of the exhaust system), care must be taken to ensure that the tailpipe trim (1) does not extend beyond the rear apron (2). Danger of burn damage! ◀

- ▶ The retrofit must be carried out with ISSS (using the latest software version!). ◀

- Connect the car with the ISSS using ICOM. Vehicle identification begins automatically.
- Confirm the control unit replacement with “No”.
- After identification, switch to the “Vehicle” menu and then select the tab “Conversions”.
- Select the conversion completed and click “Determine action plan” below.
- Select “Accept action plan”.
- Then follow the instructions.
- After programming, carry out a vehicle test and observe the instructions in the rework list.

- ▶ If the action “Enable DME/DDE” action appears in the concluding report, you must change the terminals. After changing the terminals, continue with the standard diagnostic process (continue with the car test) and delete any error memory entries. You must ensure that no error memory entries are still present. ◀

- Re-assemble the car.

8. Workshop certificate



Workshop certificate JOHN COOPER WORKS tuning kit

This is to confirm that the JOHN COOPER WORKS tuning kit has been fully installed on the vehicle below.
No additional components have been converted or retrofitted.

Part number

11 12 2 450 143	Tuning kit for F60 All4
11 12 2 450 144	Tuning kit for F60
11 12 2 445 893	Tuning kit for F54
11 12 2 445 894	Tuning kit for F54 All4

Car model:

VIN:

Name and address of the vehicle keeper:

Place, date

Signature of person responsible

Dealership (company name / stamp)