

BMW Group - AIR: 2021-04-06 / 13:53  
Retailer: 06499/01  
Model: John Cooper Works ALL4  
Vehicle identification number: WMZYV9C33J3B92158  
Development code: F60  
Model code: YV93  
Lead type: YV93

## Repair instruction

### Replacing the rear silencer (8 FRU)

18 12 030 I REP-REP-RAF5418B48-1812030 - V.2

#### 18 12 030 Replacing the rear silencer



#### Warning!

##### Risk of burning!

Only perform this repair after engine has cooled down.

##### Danger of injury!

Call on the assistance of a second person to remove the rear silencer.



#### Necessary preliminary tasks:

- Support rear silencer with a suitable jack and secure against falling down.



#### Removal:

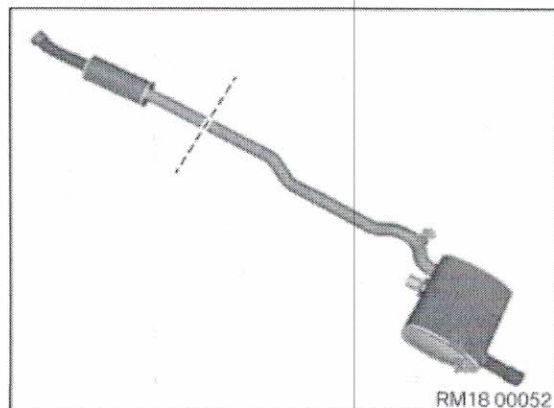

#### Note:

If the separation point line is not marked by a punch mark in the pipe, determine the separation point by means of the pipe length on the new rear silencer.

Carry over separation point to faulty rear silencer and mark.

Secure rear silencer against falling off.

Cut through exhaust pipes at marked point with a suitable tool.

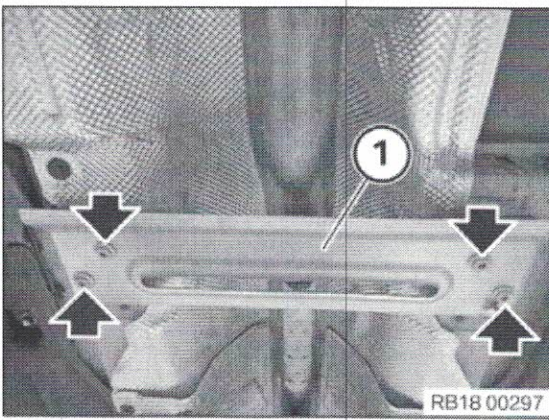

Release screws along the arrows.

Remove connection carrier (1).

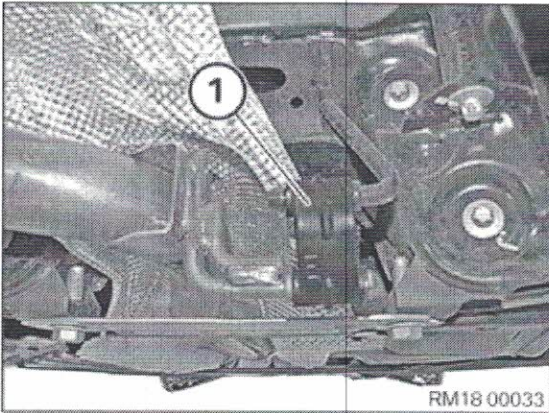

Spray rubber mount (1) with lubricant and detach from exhaust system.

Replaced damaged rubber mounts.

Parts: Rubber mount

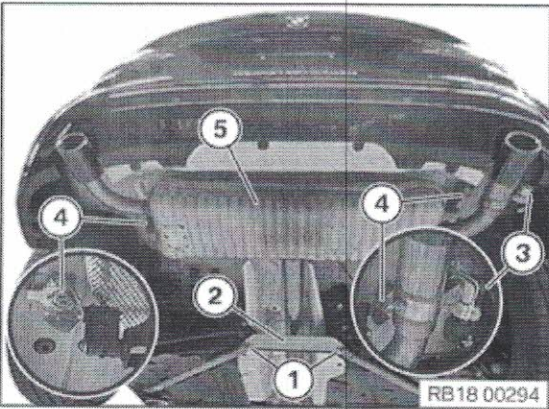

Loosen screw (1).

Remove cross strut (2) on the rear axle.

Release nut (4) on the rear left body.

Release nut (4) on the rear right body.

Unlock and release connector (3) from controller drive for exhaust flap.

Remove rear silencer.

Replaced damaged rubber mounts.

Parts: Rubber mount



Installation:

Tighten nut (4) on the rear left body.

Tighten nut (4) on the rear right body.

Tightening torque 18 20 2AZ



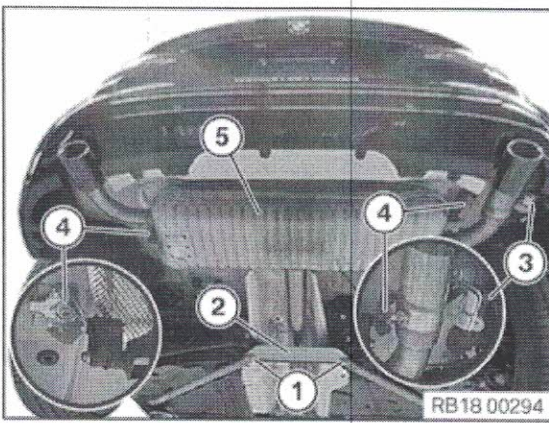

Connect and lock connector (3) of the controller drive for exhaust flap.

Connector (3) must engage audibly.

Remove cross strut (2) on the rear axle.

Tighten screw (1).

Tightening torque 18 30 6AZ

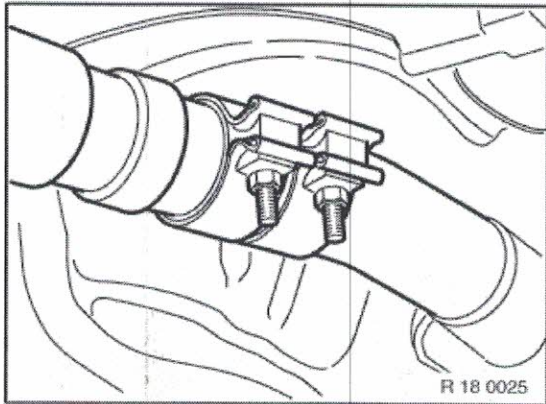

Adjust new rear silencer and connect by clamp to centre silencer.

Centre clamp and tighten down.

Tightening torque 18 20 3AZ.

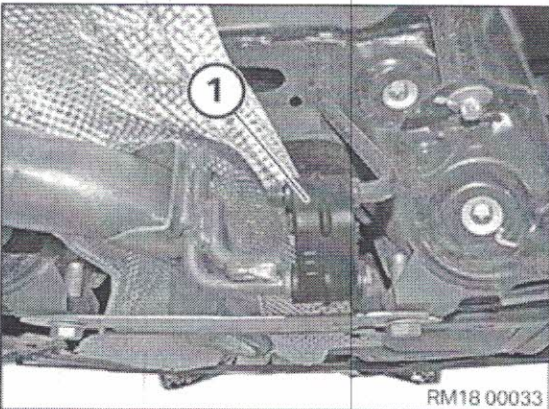

Connect rubber mount (1) to rear silencer.

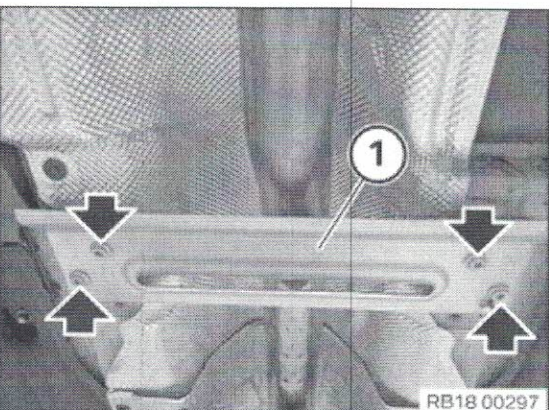

Install connection carrier (1).

Tighten screws along the arrows.

Tightening torque 18 30 5AZ.

Required follow-up work:



- Check exhaust system for leak tightness.