

Adjustments

⚠ Warning!

Before driving, always make sure that the basic settings made by Öhlins are according to recommended Set-up Data. Read about adjustments and setting up in the Öhlins Owner's Manual before you make any adjustments. Contact an Öhlins dealer if you have any questions about setting up the shock absorber.

The standard preload is 8 mm from a free length of 170 mm, giving 162 mm installed length, see fig ④.

Set-up Data

Recommended set-up

Rebound 10 clicks
Spring preload 8 mm
Shock absorber length 403 mm

Spring

Spec H170, ID65, 70 N/mm

The actual vehicle height

With the height adjuster in their standard positions, the vehicle is lowered approximately 18 mm when compared to the original suspension. As the height adjuster is turned one rotation, the position moves 2.0 mm.

⚠ Warning!

The adjustment range is the standard position ± 10 mm.

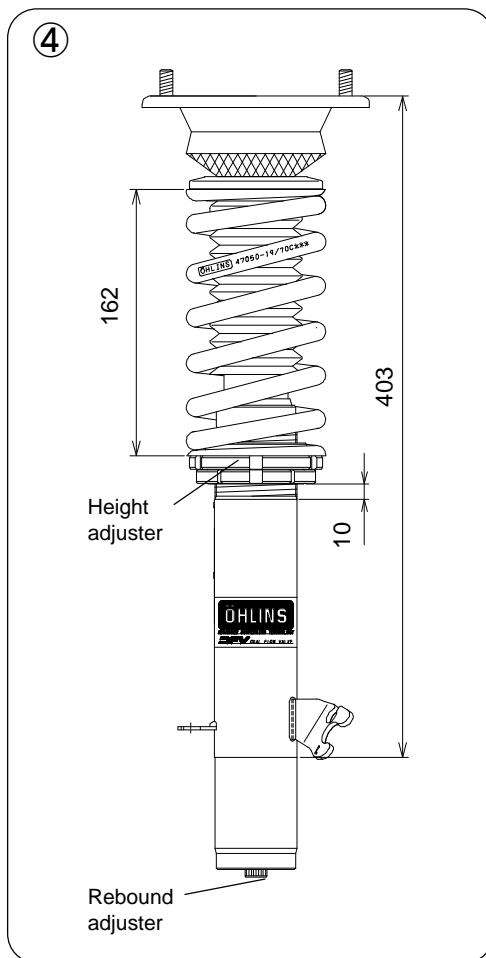

Before installing this product, check the contents of the kit. If anything is missing, please contact an Öhlins dealer.

Kit Contents	Pcs.
Shock absorber	2
Upper spring seat	2
Dust boot	2
Spring	2
Nylon nut M14	2
USED FOR BOTH FRONT AND REAR	
C-spanner	2
Öhlins sticker	1
Öhlins Owner's Manual	1

Please note that during storage and transportation, especially at high ambient temperature, some of the oil and grease used for assembling may leak and stain the packaging. This is in no way detrimental to the product, wipe off the excess oil/grease with a cloth.

⚠ Warning!

Before installing this product, read the Öhlins Owner's Manual. The shock absorber is an important part of your vehicle and will affect the stability.

© Öhlins products are subject to continuous improvement and development, therefore, although these instructions include the most up-to-date information available at the time of printing, minor updates may occur.

To find the latest information contact your Öhlins distributor. Please consult your Öhlins dealer if you have any questions regarding the contents in this document.

Part no. BMSMI20_0
Issued 2011-08-01



© Öhlins Racing AB. All rights reserved. Any reprinting or unauthorized use without the written permission of Öhlins Racing AB is prohibited.

Öhlins Racing AB



www.ohlins.com

Shock Absorber Kit for BMW MINI (R56)

BMS MI20 front Mounting Instructions



ADVANCED SUSPENSION TECHNOLOGY

How to install

⚠ Warning!

It is advisable to have an Öhlins dealer install the shock absorber.
When installing, read your Vehicle Service Manual.



1 Raise the vehicle and put it on jack stands.

⚠ Warning!

Ensure that it is securely supported.

2 Remove the front wheels.

3 Remove the stabilizer links, the brake hoses and the ABS cords from the standard struts.

4 Loosen the bolts for the lower strut attachments.

⚠ Caution!

Support the wheel hubs in an appropriate way on each side of the vehicle so that the brake hoses can not be damaged.

5 Loosen the upper attachments. Remove the original struts from the car.

6 Cut the dust boot 40 mm from the lower end with a pair of scissors according to fig ②.

7 Tighten the lower spring seat and the lock nut to 50 - 60 Nm. Fit the dust boot, the spring and the upper spring seat to the strut according to fig ①. Fit the std washer and std lower bearing spacer, the std top mount and the top nut. Tighten the top nut to 35 - 40 Nm.

8 Install the Öhlins McPherson struts on the vehicle.

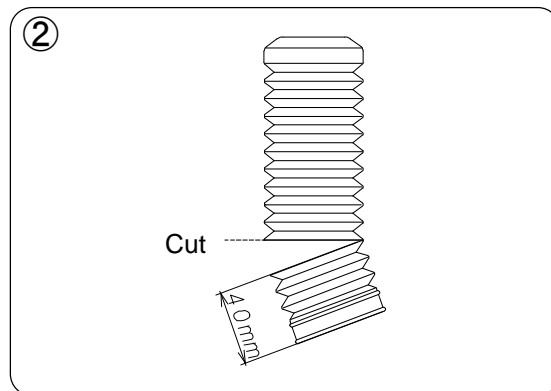
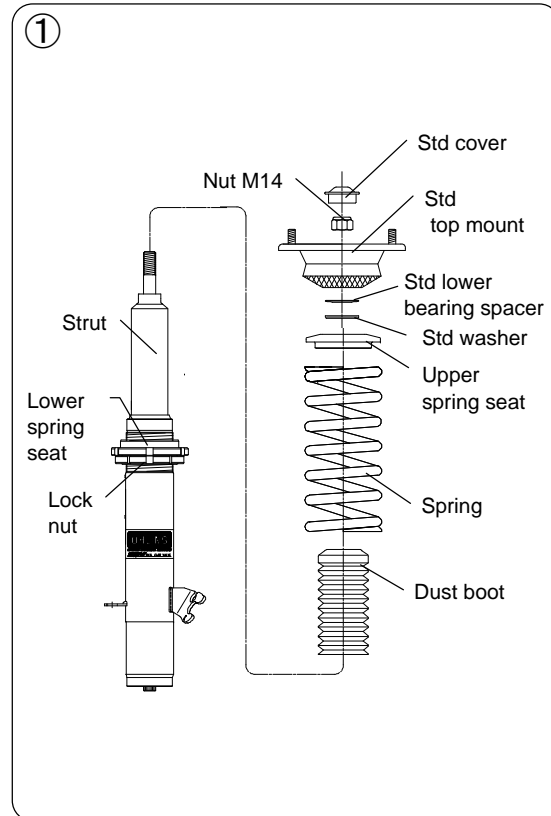

9 Mount the standard stabilizer links, the standard brake hoses and the standard ABS cords to the Öhlins struts according to fig ③.

10 Fasten the upper attachments.

👁 Note!

When tightening the top mount nut, the shock absorber shaft must be held in position with a 5 mm Allen key.

11 Raise the wheel hub with a jack to remove the free play of the lower strut attachment bolts before tightening them.

👁 Note!

Make sure that all bolts are tightened to the correct torque and that nothing fouls or restricts movement of the strut when it is being fully compressed or extended. Test this over the whole steering range from lock to lock.

12 Make sure that all removed parts are reinstalled in the same way as they were before the installation of the Öhlins shock absorber.

How to install

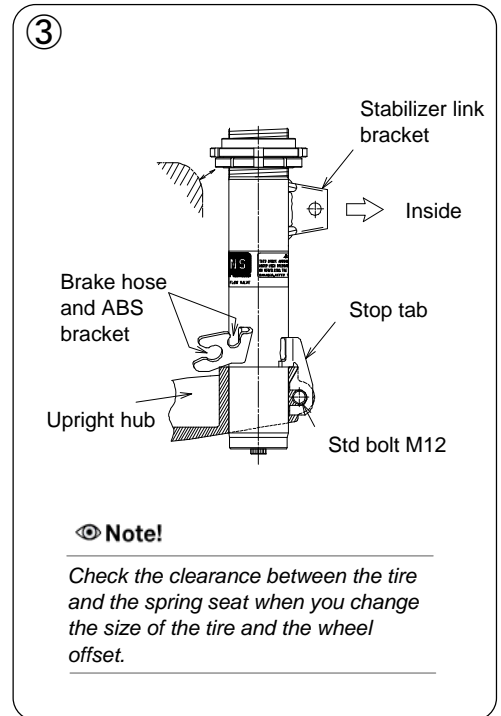

Adjustments

⚠ Warning!

Before driving, always make sure that the basic settings made by Öhlins are according to recommended Set-up Data. Read about adjustments and setting up in the Öhlins Owner's Manual before you make any adjustments. Contact an Öhlins dealer if you have any questions about setting up the shock absorber.

The standard preload is 10 mm from a free length of 200 mm, giving 190 mm installed length, see fig ⑤.

Set-up Data

Recommended set-up

Rebound 10 clicks
Spring preload 10 mm
Shock absorber length 425 mm

Spring

Spec H200, ID65, 60 N/mm

The actual vehicle height

With the height adjustments in their standard positions, the vehicle is lowered approximately 18 mm when compared to the original suspension. As the height adjuster is turned one rotation, the position moves 2.0 mm.

⚠ Warning!

The adjustment range is the standard position ± 15 mm.

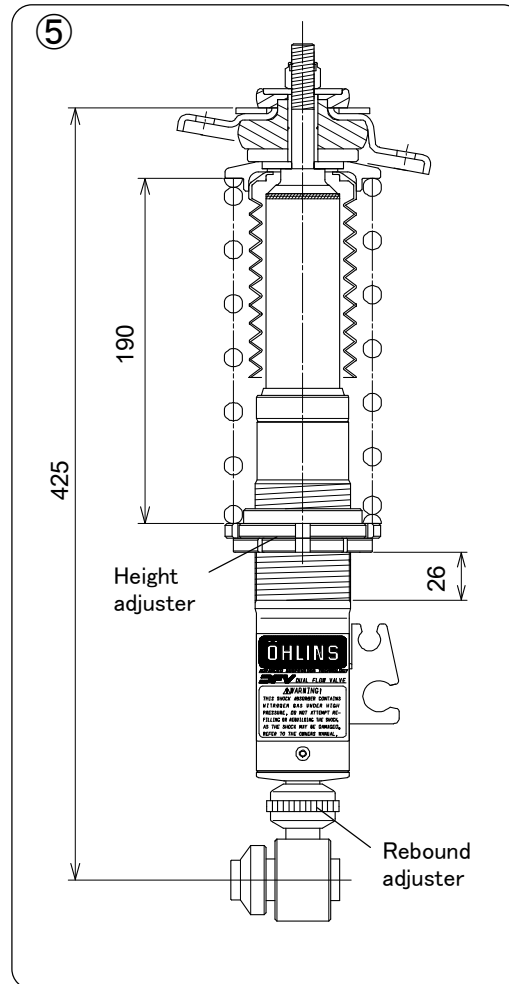

Before installing this product, check the contents of the kit. If anything is missing, please contact an Öhlins dealer.

Kit Contents	Pcs.
Shock absorber	2
Dust boot	2
Upper spring seat	2
Spring	2
Spacer $\varnothing 60$, t7	2
Spacer $\varnothing 16$, t37	2
Lock nut M12	2
Washer t3.2	2
Special spacer with taper	2

USED FOR BOTH FRONT AND REAR

C-spanner	2
Ölines sticker	1
Öhlins Owner's Manual	1

Please note that during storage and transportation, especially at high ambient temperature, some of the oil and grease used for assembling may leak and stain the packaging. This is in no way detrimental to the product, wipe off the excess oil/grease with a cloth.

⚠ Warning!

Before installing this product, read the Öhlins Owner's Manual. The shock absorber is an important part of your vehicle and will affect the stability.

Öhlins products are subject to continuous improvement and development, therefore, although these instructions include the most up-to-date information available at the time of printing, minor updates may occur.

To find the latest information contact your Öhlins distributor. Please consult your Öhlins dealer if you have any questions regarding the contents in this document.

Part no. BMSMI20_0
Issued 2011-08-01



© Öhlins Racing AB. All rights reserved. Any reprinting or unauthorized use without the written permission of Öhlins Racing AB is prohibited.

Öhlins Racing AB



www.ohlins.com

Shock Absorber Kit for BMW MINI (R56)

BMS MI20 rear Mounting Instructions



How to install

⚠ Warning!

It is advisable to have an Öhlins dealer install the shock absorber.

When installing, read your Vehicle Service Manual.



1
Raise the vehicle and put it on jack stands.

⚠ Warning!

Ensure that it is securely supported.

2
Remove the rear wheels.

3
Remove the lower and the upper attachments and remove the original shock absorbers.

4
Cut the dust boot 52 mm from the lower end with a pair of scissors according to fig ②.

5
Tighten the lower spring seat and the lock nut to 50 - 60 Nm.
Fit the dust boot, the spring, the upper spring seat, the spacers and the std top mount according to fig ①. Tighten the lock nut to 30 Nm.

👁 Note!

When tightening the top mount nut, the shock absorber shaft must be held in position with a 5 mm Allen key.

6
Install the Öhlins shock absorbers on the vehicle according to fig ③.

7
Fasten the upper attachments.

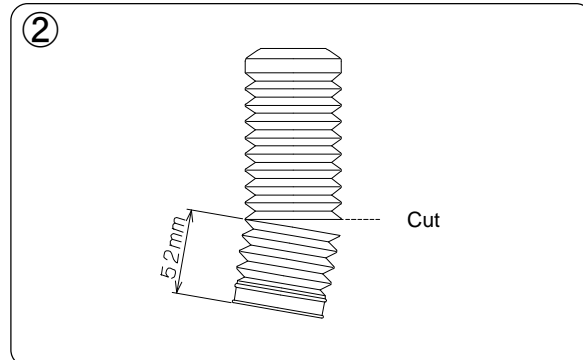
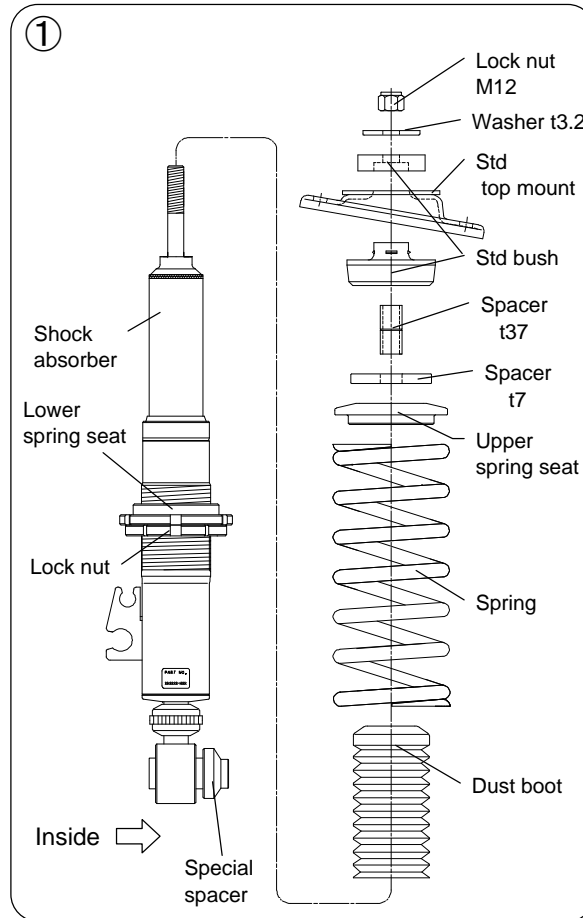

How to install

👁 Note!

Make sure that all bolts are tightened to the correct torque and that nothing fouls or restricts movement of the shock absorber when it is being fully compressed or extended.

8

Make sure that all removed parts are reinstalled in the same way as they were before the installation of the Öhlins shock absorber.

